



MAXUS
eDELIVER 9

MAXUS
eDELIVER 3



MAXUS eDELIVER RANGE

FEATURING MAXUS INTELLIGENCE ONBOARD



MANUFACTURER

Innovative, thought-leading, and future-focused, Shanghai Automotive Industry Corporation (SAIC) is the largest automotive group in China, and is the name behind the MAXUS (formerly LDV) brand.

Based in Shanghai, SAIC produces almost seven million vehicles each year for both domestic and international markets and is a Fortune Global 500 listed company with almost 100,000 employees.

With a long history tracing back to the 1940s, SAIC saw real growth from the mid-1980s onwards following a number of partnerships that allowed it to produce competitive vehicles by utilising the latest technology.

The company has a number of well-known brands within its portfolio including, since 2010, the acclaimed MAXUS range of LCVs. SAIC has invested more than €2 billion in this brand, with a strong focus on safety, innovation and the introduction of new products to the range, including a suite of EVs that are already setting the standard for the future of eco-fuelled commercial motoring.

Since acquiring LDV, these LCVs were manufactured under the MAXUS moniker for the home market in China in addition to selected left hand drive markets in Europe such as Spain, Belgium and The Netherlands. In April 2020, LDV rebranded as MAXUS across right hand drive Europe, coinciding with the launch of the all-new eDELIVER 9 and the newest EV in the brand's stable, the eDELIVER 3, thereby consolidating the brand's presence across Europe, China and beyond.

With an even brighter future ahead, SAIC's key areas of development are electrification, car sharing, connectivity and globalisation. Today, there are eight major automotive groups within SAIC, including SAIC MAXUS.

SAIC's vision is to continue to build an innovative, globally-recognised company that pioneers the future of the automotive industry, actively promoting new energy vehicles.

DISTRIBUTOR

You are the expert in your field but when it comes to automotive expertise, The Harris Group is here to guide you through your search for the right vehicle for your business. One of the longest-established automotive distribution and assembly companies in Ireland and the UK, The Harris Group was founded in 1961 and is an industry leader in the commercial and fleet sectors.

The privately-owned company is best known for its commercial vehicle brands that include Hino, Sinotruk, Higer, Isuzu, AOS and Crusader. In 2016, The Harris Group acquired the distribution rights to MAXUS (formerly LDV) across right hand drive Europe and the range of LCVs, which includes market-leading electric vehicles, has taken the market by storm.

The Harris Group has developed an unrivalled reputation for service excellence in the UK and Ireland, which comes from almost 60 years of experience. Harris is the distributor for the MAXUS range of vehicles in the UK, Ireland, Channel Islands, Isle of Man, Malta and Cyprus.



OUR NETWORK

With a strong dealer network of dedicated and experienced commercial vehicle specialists, we offer the highest standards of expertise whether you are looking to buy one van or an entire fleet.

Following a high-profile relaunch of the LDV brand in 2016, Harris is continuing to build its network across all right hand drive markets in Europe.

Today, the Group represents the MAXUS range in a total of seven territories, including the UK, Ireland, Channel Islands, Isle of Man, Malta and Cyprus, with the company focussed on a big drive to expand the dealer network throughout the UK.

Every dealer within the company's network operates with a strong focus on after-sales activities, thereby ensuring complete customer satisfaction.

Check out www.saicmaxus.co.uk to find your local dealer.





HIGH POWER LOW ENERGY MOTOR

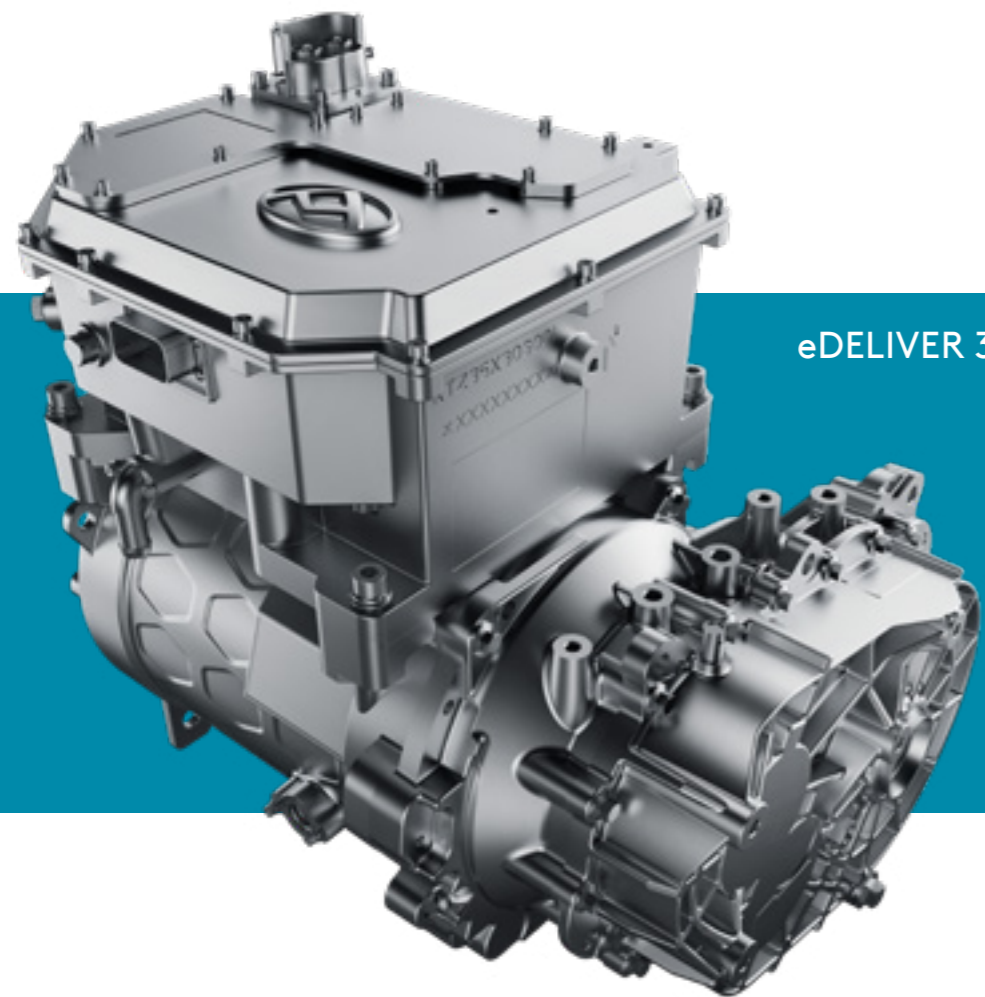

eDELIVER 3

ELECTRIC POWERTRAIN

HIGH POWER LOW ENERGY MOTOR

The maximum power is 90kW; the peak torque is 255N·m; the acceleration time of 0-100km/h is 11s.

PROVIDE DC + AC DUAL CHARGING MODE

DC mode: 45 minutes can charge 80% of electricity, 80 minutes can be charged to 100%.

MAXUS eDELIVER 3



35kWh BATTERY

CATL



50.23kWh BATTERY

SAIC are the leaders in the technical revolution, continually leading the way in the development of new technology and solutions for the automotive industry.

A part of that revolution is being the market leaders in battery technology, we have developed a number of battery options for the eDELIVER 3, by using various battery cooling methods, which allows us to reduce charging time DC 45mins (5%-80%) AC 5hrs, extend battery life and increase the operating range.

The eDeliver 3 comes with a 90KW/255Nm motor, AC/DC charging options and a choice of 35Kw or 50.23Kw battery configurations.



MAXUS eDELIVER 3

STORAGE SYSTEM

The new Maxus eDELIVER range of vehicles offer all the storage you need to keep your cab area neat & organised. There is a place for everything, in addition to the glovebox there are storage areas in the door pockets to keep things close to hand. Larger items can be stored under the seats in both the eDELIVER 3 & the eDELIVER 9. In the eDELIVER 9 there is the added bonus of a folding seatback which reveals two further cup-holders and a handy tablet holder.

- USB port and mini jack port¹ (driver and passenger)
- Storage space under the bench seat
- Storage compartments in the doors
- Cup holder (driver and passenger)
- 12 V power socket





The Infotainment System takes the MAXUS eDELIVER 3 driving experience from ordinary to extraordinary

MAXUS eDELIVER 3 model offers a pure driving experience that any van driver will appreciate. Professional drivers have busy and often long days, and this is why the eDELIVER 3 cabin area offers all the comfort and practicality of a mobile office space.

Packed with cutting edge technology and practical features, you'll have everything you need and all operated at the touch of a button via touch screen. In addition to the radio functions, the high specification includes USB ports for both the driver and passenger, so you can always

remain connected whether by laptop or by simply hooking up your smartphone to the system. A ready-to-go mobile office space. Use the link to access all your apps and emails.

MAXUS
eDELIVER 3

MAXUS
eDELIVER 3

MULTI-FUNCTION STEERING WHEEL

MULTI FUNCTION STEERING WHEEL

Make use of important features using the multi-function steering wheel whilst keeping full control of your vehicle. Answer and hang-up your mobile phone, control the volume of the stereo and manage the cruise control functions whilst keeping both hands on the steering wheel.

CRUISE CONTROL

Cruise Control allows you to set the cruising speed and keep it constant.



DRIVERS' ENVIRONMENT COMFORT AND SAFETY

COOL, CALM AND IN CONTROL

Stay cool at all times with the eDELIVER smart air conditioning system with our ever-changing climate, the importance of a good air conditioning system was always going to be a factor when it came to designing this vehicle. The eDELIVER models include manual air conditioning for your comfort and the comfort of your passengers. The variable control of the air conditioning system ensures that the temperature can be adjusted easily and quickly. So you can always rely on a pleasant work environment, whatever the weather.

Unique design, aluminium monocoque frame, composite plastic front panels for maximum payload and durability.



COMPREHENSIVE SAFETY STANDARDS

At MAXUS, safety is paramount and the eDELIVER 3 meets all European commercial vehicle collision design standards.

Advanced driver assistance system as standard with the latest generation of ESP Electronic Stability Program and delivers comfort and peace of mind in any situation.

- 7 Inch Touch Screen
- Daytime Running Lamp
- Driver and Passenger Airbag*
- Driver-S/Belt Reminder
- Eco Drive Mode Setting
- ESC (ESP)
- Hand Brake
- Multifunction Steering Wheel
- Visual Reversing Camera
- Rear Proximity Sensor
- Tyre Pressure Monitoring System

MAXUS
eDELIVER 3



MAXUS eDELIVER 3

eDELIVER 3 MODEL Standard Equipment

- 2 Driving Modes
- 3 Energy Recovery Modes
- 4 Cargo Area Floor Strapping Rings
- Air Conditioning
- Alloy wheels (Optional)
- Automatic On/Off Headlights
- Bluetooth
- Cargo Area Partition
- Cruise Control
- Daytime Running Lights
- Driver Airbag
- Driver Seatbelt Lock Reminder
- Electric Adjustment Of Outside Mirror
- Electric Power Assisted Steering
- Electric Windows

- ESC - Electronic Stability Control
- Front & Rear Ventilated Discs
- Front McPherson Independent Suspension
- Front Passenger Airbag
- Handbrake
- Heated Seats
- Height Adjustable Steering wheel
- Immobiliser
- Multifunction Steering Wheel
- Rake Adjustable Steering Wheel
- Rear Leaf Spring Suspension
- Reversing Camera
- Rear Parking Sensors
- Stainless Steel Cargo Area Floor
- Ternary Polymer Lithium Battery
- Touch Screen 7 inch



* No rear camera or sensors on chassis models

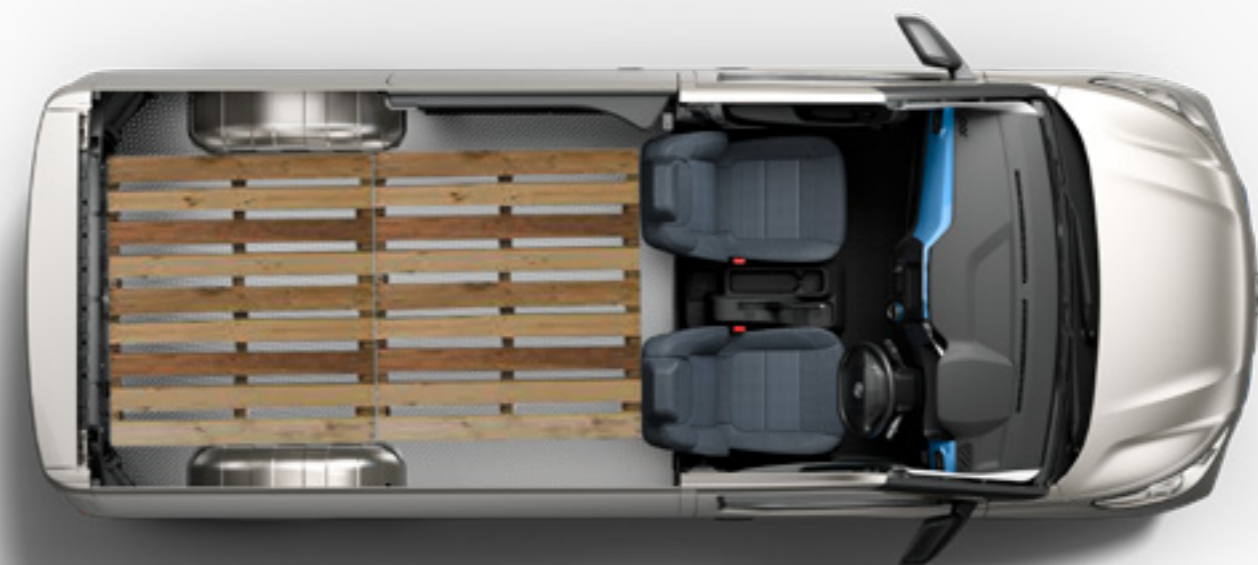

LOADING COMPARTMENT

The width of the compartment is 1665mm. The cargo area offers optimal ease of loading with the short wheelbase for the van of 4.8 cubic metres.



eDELIVER 3 MODEL Body Structure

The design uses aerodynamic principles to reduce wind resistance and lighten the entire vehicle. A large number of aluminum alloys and polymer composite materials are used. Strong design with emphasis on strength and payload

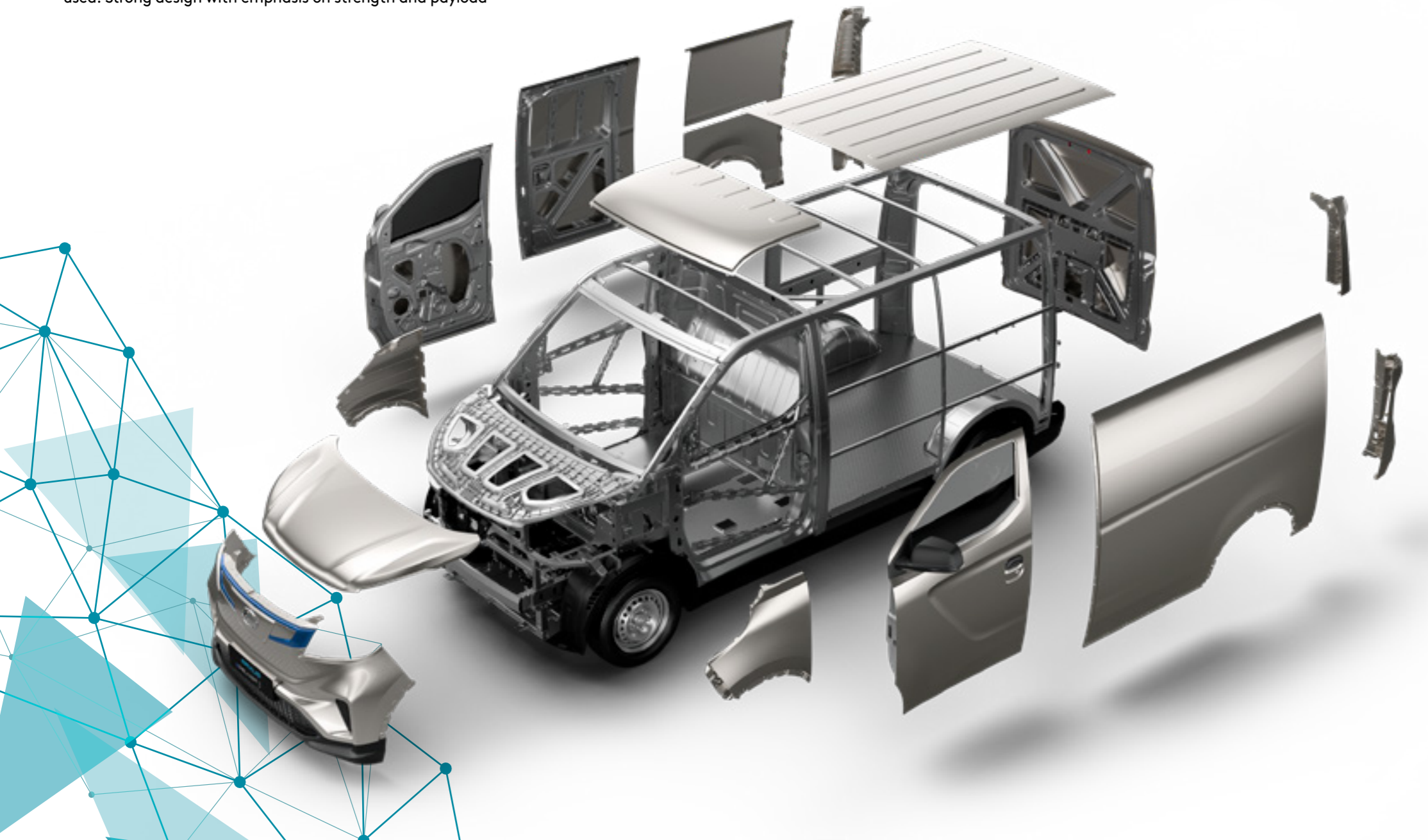

MAXUS eDELIVER 3 VARIANTS

Specifications

MAXUS eDELIVER 3	SWB 35kWh	SWB 50.23kWh	Chassis cab 50.23kwh
WEIGHTS			
GVM (kg)	2310	2500	2600
Kerb Weight (excluding driver) (kg)	1445	1425	1480
Max front axle load (kg)	1180	1170	1180
Max rear axle load (kg)	1260	1460	840-1095
Payload (kg)	865	945	1202
Max roof load (kg)	75	75	NA
Towing capacity (unbraked) (kg)	750	750	NA
Towing capacity (braked) (kg)	1200	1090	NA
ENGINE			
Drive type	RHD	RHD	RHD
Number of seats	2	2	2
Rated power/peak power (kW)	40/90	40/90	40/90
Rated torque/Max. torque (N.m)	125/255	125/255	125/255
Max speed (kmph /mph)	120/75	120/75	90/56
Acceleration 0-100km/h (sec)	11	12	12
GEAR RATIOS			
Forward	9.348	9.348	TBC
Reverse	9.348	9.348	TBC
DIMENSIONS			
Dimension : L *W *H (mm)	4555 X 1780 X 1895	4555 X 1780 X 1895	5090x1780x1885 (without box) 5156x1810x2370 (with max box)
Wheel base (mm)	2910	2910	3285
Length cargo space (mm)	2180	2180	2400
Max width cargo space (mm)	1665	1665	1800
Max width cargo space between wheel arches (mm)	1220	1220	1220
Max height cargo space (mm)	1330	1330	TBC
Max body height (mm)	N/A	N/A	2370
Slide door width (mm)	710	710	N/A
Slide door height (mm)	1230	1230	N/A
Turning radius (m)	5.87	5.87	6.53
Cargo volume (m ³)	4.8	4.8	TBC
CHARGING			
Charging time(AC 100%) h	6	8	8
Charging time (DC 80%) min	45	45	45
Battery capacity (kWh)	35	50.23	50.23
Energy consumption WLTP combined (Kwh/100km)	24.36kwh/100km	23.63kwh/100km	N/A depends on body style
RANGE			
WLTP City Range	141 Miles/227 KMS	213 Miles/344 KMS	N/A depends on body style
WLTP Combined Range	99 Miles/159 KMS	151 Miles/243 KMS	N/A depends on body style

LOADING COMPARTMENT eDELIVER 3



MAXUS eDELIVER 3

eDELIVER 3 MODEL

3 years paint warranty
10 years anti - corrosion warranty

MAXUS continuously invests in the use of new materials, state-of-the-art painting and cutting-edge manufacturing processes to ensure our vehicles deliver for our customers today, tomorrow and for many years to come.



Blanc White



Aurora Silver Metallic body colour*



Obsidian Black Metallic body colour*



* denotes cost option

SWB (4555mm Overall Length)

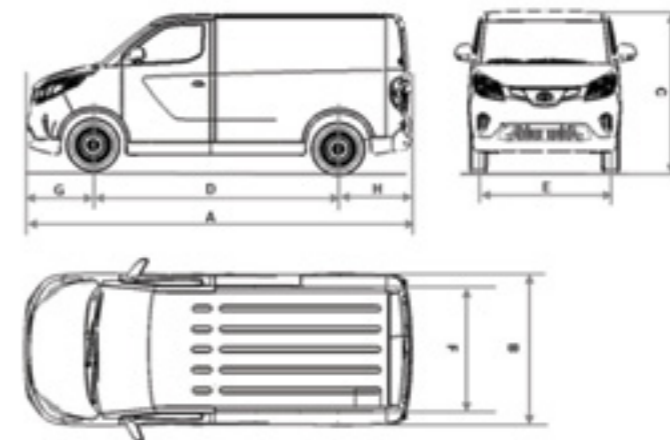

Length (A)	4555
Width (B)	1780
Height (C)	1895
Wheel Base (D)	2910
Track - 1st axle (E)	1548
Track - 2nd axle (F)	1553
Front Overhang (G)	780
Rear Overhang (H)	865

CHASSIS (5156mm Max Overall Length (1810mm Max Body Width))

Length (A)	5090
Width (B)	1780
Height (C)	1885
Wheel Base (D)	2910
Track - 1st axle (E)	1548
Track - 2nd axle (F)	1553
Front Overhang (G)	780
Rear Overhang (H)	1025



**ALL
ELECTRIC**

#allelectricmaxus



HIGH POWER 150KW LOW ENERGY MOTOR

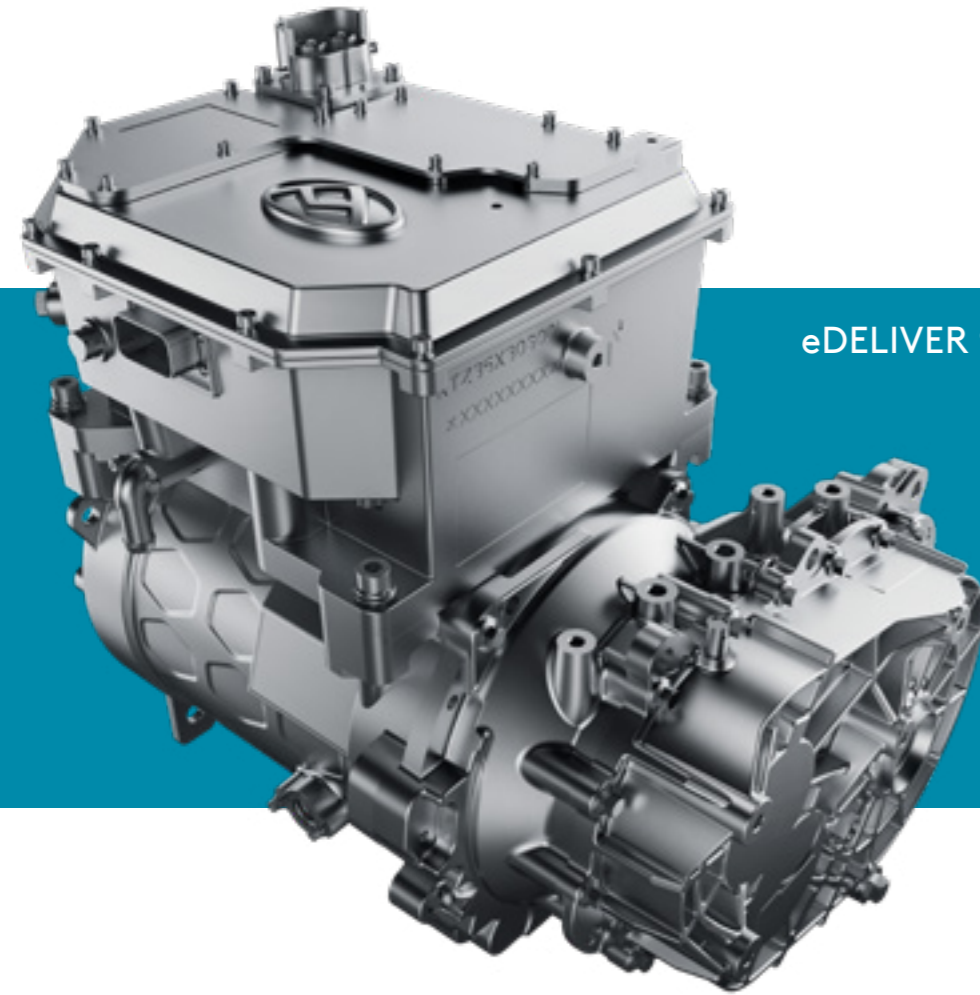

eDELIVER 9

ELECTRIC POWERTRAIN

HIGH POWER LOW ENERGY MOTOR

The Maximum Power is 150Kw , the peak torque is 310Nm” and change the 0-100kms/hr to 0-50kms/hr and the time from 11secs to 5.7secs.

PROVIDE DC + AC DUAL CHARGING MODE

DC mode: 45 minutes can charge 80% of electricity,80 minutes can be charged to 100%.

MAXUS eDELIVER 9



51.5KWH BATTERY

CATL



72kWh OR 88.55kWh BATTERY

SAIC are the leaders in the technical revolution, continually leading the way in the development of new technology and solutions for the automotive industry.

A part of that revolution is being the market leaders in battery technology, we have developed a number of battery options for the eDELIVER 9, by using various battery cooling methods, which allows us to reduce charging time DC 45mins (5%-80%) AC 5hrs, extend battery life and increase the operating range.

The eDELIVER 9 comes with a 150Kw / 310Nm motor and a choice of 3 batteries configurations, 51.5Kwh, 72Kwh and 88.55 Kwh with A/C & DC charging as standard.



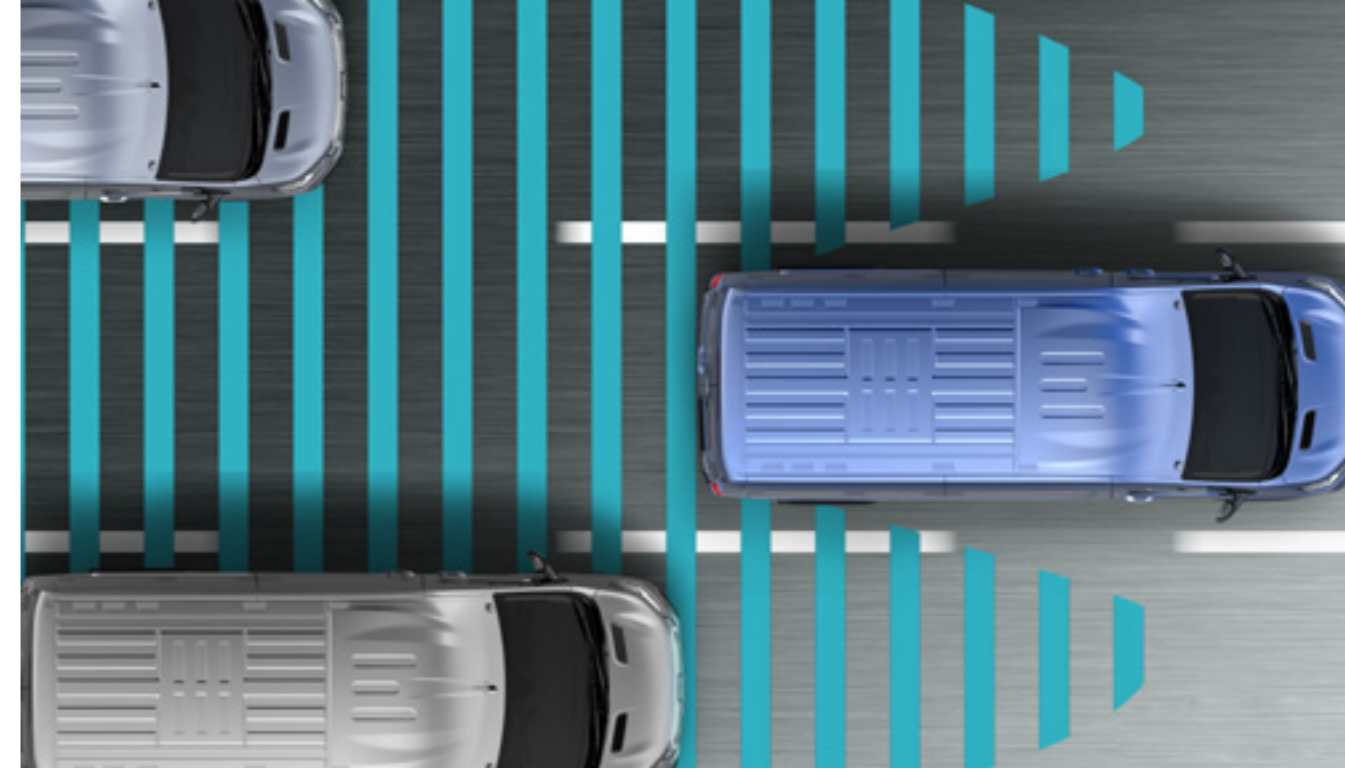

MAXUS
eDELIVER 9

eDELIVER 9 MODEL Standard Equipment



- 10 Inch Touch Screen
- 16" Alloy Wheels
- 236° Opening Angle (with Limited Gemel)
- 8-direction Adjustable Driver's Seat with armrest
- Adjustable non-Pretightening Belt
- Adjustable Overspeed Alarm
- Air conditioning
- Auto Latch (8mp/h)
- Automatic Emergency Braking System
- Automatic Off Headlights
- B Column Full Steel Unglazed Partition
- Blind Area Monitoring System
- Body Colour Handles
- Central Lock
- Chrome Front MAXUS Hexagonal Signature Grill
- Cruise Control System
- Driver and Passenger Safety Belt Buckle Reminder

- Driver Seat Airbags
- Driving Model (Power/Normal/Eco)
- Duel Cargo light
- eCall
- Electric Front Windows
- Electric Heating Side Mirrors (Natural Colour)
- Electric Power Steering
- Electric Side Step (Optional)
- ESP+EBA+BAS+HHC
- Front Body-Colour Bumper
- Front Double Curtain Airbag
- Front Passenger Airbags
- Ignition-off Auto Unlock
- Infotainment System
- Intelligent Anti-Theft Security System
- Lane Change Assist System
- Lane Departure Warning System

- LED Day Time Running Light
- LED Headlights
- Multifunction steering wheel
- Keyless Entry and Stop / Start System
- Parking Sensor (Front and Rear)
- Passenger Adjustable non-Pretightening Belt
- Rear Bumper Nature Colour
- Rear Fog Lamp
- Reverse Camera with Guide Assist
- Seat Fabric (Knit / Gray)
- Single-Side Sliding Door
- Load Area Tie Down Points
- Tyre Pressure Monitoring System
- Reversing Camera
- Wear Resistant Floor

* No rear camera or sensors on luxury chassis models



HIGH BEAM RECOGNITION
This manages the activation and deactivation of the main beam headlights, increasing visibility and reducing the risk of dazzling when driving at night, automatically recognising vehicles driving in the opposite direction.



ELECTRIC HEATING SIDE MIRROR
Heated electrically operated door mirrors ensure great rear visibility in all weather conditions.



STRUCTURE
9.2m laser welding, the longest in the industry. 54% high strength steel and PHS. Accumulated 2 million kilometres of whole vehicle full environment test verification

BSD + LCA-BASE VERSION
The Lane Departure Warning System can determine whether the van is changing lane, even in low-visibility weather conditions. In the event of danger, an acoustic and visual signal alerts the driver of the potential impending threat.

MAXUS eDELIVER 9 VARIANTS

Specifications

MAXUS eDELIVER 9	MH		LH			N2	MC CAB	LC CAB	LC CAB N2
	Capacity (kWh) 51.5kWh	Capacity (kWh) 72kWh	Capacity (kWh) 51.5kWh	Capacity (kWh) 72kWh	Capacity (kWh) 88.55kWh	Capacity (kWh) 88.55kWh	Capacity (kWh) 65kWh	Capacity (kWh) 65kWh	Capacity (kWh) 65kWh
WEIGHTS									
GVM (kg)	3500	3500	3500	3500	3500	4050	3500	3500	4050
Kerb Weight (excluding driver)	2300	2460	2340	2520	2640	2660	2080	2090	2185
Max front axle load (kg)	1950	1950	1950	1950	1950	1950	1950	1950	1950
Max rear axle load (kg)	1900	1900	1900	1900	1900	2300	1900	1900	2300
Payload (kg) * excluding body	1200	1040	1160	980	860	1390	*1420	*1410	*1865
Towing capacity (unbraked) (kg)	1500 (750)	1500 (750)	1500 (750)	1500 (750)	1500 (750)	1500 (750)	1500 (750)	1200 (750)	1500 (750)
ENGINE									
Drive Type	RHD/LHD	RHD/LHD	RHD/LHD	RHD/LHD	RHD/LHD	RHD/LHD	RHD/LHD	RHD/LHD	RHD/LHD
Number of seats	3	3	3	3	3	3	3	3	3
Rated power/peak power (kW)	70/150	70/150	70/150	70/150	70/150	70/150	70/150	70/150	70/150
Rated torque/Max. torque (N.m)	160/310	160/310	160/310	160/310	160/310	160/310	160/310	160/310	160/310
Max speed (mph/kmh)	62/100	62/100	62/100	62/100	62/100	56/90	100	100	56/90
Acceleration 0-50km/h (sec)	5.7	5.7	5.7	5.7	5.7	5.7	7	7	5.7
DIMENSION									
Dimension :L *W *H (mm) (A,B, C)	5546x2062x2525	5546x2062x2525	5940x2062x2525	5940x2062x2525	5940x2062x2525	5940x2062x2525	6200x2052x2290	6680x2052x2290	6680x2052x2290
Wheel base (mm) (D)	3366	3366	3760	3760	3760	3760	3760	4048	4048
Length cargo space (mm) (E)	3019	3019	3413	3413	3413	3413	-	-	-
Max width cargo space (mm) (F)	1800	1800	1800	1800	1800	1800	-	-	-
Max width cargo space between wheel arches (mm) (G)	1366	1366	1366	1366	1366	1366	-	-	-
Max height cargo space (mm) (H)	1792	1792	1792	1792	1792	1792	-	-	-
Slide door width (mm) (I)	1269	1269	1269	1269	1269	1269	-	-	-
Overhang Front (J) /Rear (k)	1020/1160	1020/1160	1020/1160	1020/1160	1020/1160	-	1020/1420	1020/1612	-
Slide door height (mm) (L)	1570	1570	1570	1570	1570	1570	-	-	-
Turning radius (m)	6.7	6.7	7.4	7.4	7.4	14.1	7.4	7.9	15.2
Cargo volume (m³)	9.7	9.7	11	11	11	11	-	-	-
CHARGING									
Charging time (AC 100%) h/POWER (7.4kW)	8	10	8	10	12	12	9	9	9
Charging time (DC 80%) min	45	40	40	40	45	45	36	36	36
Battery capacity (kwh)	51.5	72	51.5	72	88.55	88.55	65	65	65
Energy consumption WLTP combined (kWh/100km)	29.44	31.06	29.44	31.06	31.03	31.03	N/A* depend on body style	N/A depend on body style	N/A depend on body style
RANGE									
WLTP city Miles / (kms)	147 (237)	179 (288)	147 (237)	179 (288)	219 (353)	219 (353)	N/A*	N/A*	N/A*
WLTP Combined Miles / (kms)	112 (180)	146 (235)	112 (180)	146 (235)	185 (296)	185 (296)	N/A*	N/A*	N/A*

MAXUS eDELIVER 9

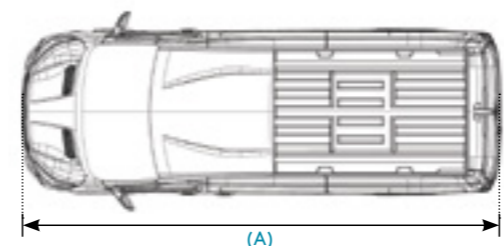

(A)

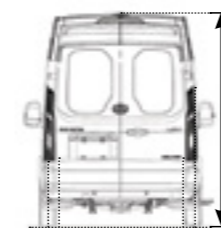

(C)

(F)

(G)

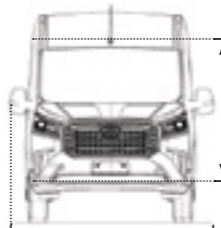

(L)

(B)

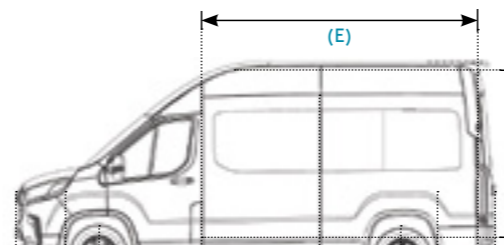

(E)

(H)

(J)

(D)

(I)

(K)

eDELIVER 9

CUSTOM VEHICLE OPTIONS

MAXUS eDELIVER 9



If your business requires a bespoke vehicle to match your specific working environments, MAXUS has a network of specialist converters that will work with you to create the conversion that best suits your needs. Whether an electric vehicle, drop side, tipper, ambulance, wheelchair accessible minibus or camper van, MAXUS offers you the choice to work with our in-house teams or one of our nationwide dealers or converters. Whichever avenue you choose, MAXUS will work with you through the entire process, from design to delivery, letting you concentrate on more important business - your business.

Working with MAXUS offers your business the reassurance and guarantee that each and every step of the way your design needs will be dealt with by professionals in this field.

TAKE YOUR PICK

3 years paint warranty. 10 years anti - corrosion warranty.

MAXUS continuously invests in the use of new materials, state-of-the art painting and cutting-edge manufacturing processes to ensure our vehicles deliver for our customers today, tomorrow and for many years to come. The eDELIVER 9 come with 5 paint colour options standard colour Blanc White, and a cost option for metallic / customised paints, Ocean Blue, Aurora Silver, Obsidian Black and Olive Brown * denotes cost option.



Blanc White



Olive Brown
Metallic body colour*



Obsidian Black
Metallic body colour*



Ocean Blue
Metallic body colour*



Aurora Silver
Metallic body colour*

Images shown are for illustration purposes only.

MAXUS SERVICES



Warranty

Basic vehicle warranty covers the non Electric Vehicle parts – 5yrs 60,000 miles (100,000 Kms)

Electric vehicle drive train warranty covers all the electric vehicle parts – 5yrs 60,000 miles (100,000 Kms)

Electric vehicle battery (Li-Ion) capacity coverage covers capacity loss – 8yrs 100,000 (160,000kms)

For T&C's see page 3 of the "Service /Warranty Handbook

Your vehicle is covered by a warranty package for 5 years 60,000 miles (96,000kms) and the Battery 8 years 100,000 miles (161,000 Kms) from date of first registration. Your MAXUS Dealer or MAXUS EV Dealer is able to repair or replace, without charge, parts that are found to have a material or assembly defect that is recognised by MAXUS. The paintwork warranty runs for 3 years and the anti-corrosion warranty for 10 years.

For full warranty terms and conditions please visit MAXUS website /warranty.

MAXUS Assist

5 Years MAXUS Assistance (RAC)

Should you need it, we'll provide emergency roadside repairs or recover you to the nearest MAXUS Dealer or MAXUS EV Dealer. This service is available 24 hours a day and is provided for 5 years or 60,000 miles (100,000 Kms) from the date of first registration, whichever comes first. Assistance is provided within the UK & Northern Ireland only at roadside and home and includes national recovery to nearest dealer or home dealer. Assistance applies to mechanical or electrical defects which are covered by warranty.

Service Intervals

eDELIVER 3 and eDELIVER 9 Service: 24 months or 18,000 miles (30,000 Kms) thereafter. MAXUS Dealer Network Services. No-one is better placed than MAXUS to maintain, fit and repair your eDELIVER fast. MAXUS Dealers repair and maintenance and offer a full year's guarantee on Original MAXUS Parts. And don't forget to have a look at our wide range of additional equipment and accessories!

MAXUS Auto Care

MAXUS Auto Care is an innovative Service, Maintenance & Repair product that supplies business customers with a fully supported, hassle-free service and maintenance package. MAXUS Auto Care is a "Pay-As-You-Go" product that ensures your vehicle is maintained by MAXUS technical experts when work is required.

MAXUS Auto Care provides the following benefits:

- Full service, maintenance and repair cover
- Tyres can be included within the contract at an additional fixed cost
- Ancillary equipment can also be included (at an additional fixed monthly cost)
- Excludes: Damage/Neglect/Abuse/Glass and bulbs
- A fixed, pre agreed pence per mile rate
- No excess mileage charges at the end of the contract
- No pooled mileage administration
- Minimises downtime

For more information and to obtain a quote based on your requirements, please speak to your local MAXUS Auto Care dealer or visit the MAXUS website.

Customer Relations

MAXUS knows the value of communicating with its business customers and we have established effective ways to support you and your business. Speak to your local MAXUS dealership, if you are not completely satisfied, please contact the MAXUS UK office.

(Mon-Fri 9.00am to 5.30pm, Closed on Bank Holidays).

You can also visit our website:
www.saicmaxus.co.uk
www.saicmaxus.ie

Or write to us at: maxusfleet@saicmaxus.co.uk

MAXUS HQ Ireland
Harris Maxus UC, Naas Road, Dublin, D12 V065

MAXUS HQ United Kingdom
Harris Maxus, 719 Eddington Way, Birchwood Park, Warrington, WA3 GBA

MAXUS Finance Options

There is a wide variety of ways to purchase a new vehicle.

Your local MAXUS dealer can help arrange :
HP, Contract Hire, Leasing

Finance offers available to all , so whether you're a fleet buyer or private buyer, MAXUS dealers are ideally placed to tell you which plan or combination of plans best suits your needs and circumstances.

Subject to status, terms and conditions apply.

Contact your local MAXUS dealer or MAXUS Website for further details.





Your local dealer

Thomas McCrea & Co Ltd
12 Ballyrobert Road, Newtownabbey
Co. Antrim, BT36 4TL
028 9034 2973



HARRIS MAXUS U.C.

FIND US @



MAXUS Disclaimer:

Images shown in this brochure are for illustration purposes only. Actual vehicles may differ and are subject to change. Specifications, standard equipment, options, fabrics and colours are subject to change without notice. Some features may be unavailable when your vehicle is built. Some vehicles are pictured with options that may be available at extra cost or may not be available on certain models. Ask about availability of options and verify that the vehicle you ordered includes the equipment you ordered. *5 year /60,000 mile warranty and 8 year 100,000 mile battery warranty. Terms and conditions apply.